

DO NOT SCALE DRAWING	SHEET 34 OF 39			ConSet A/S Industrivej 23 DK-6900 Skjern Denmark
UNLESS OTHERWISE SPECIFIED: DIMENSIONS ARE IN MILLIMETERS TOLERANCES: LINEAR: According to ANGULAR: DIN 7168-m	DRAWN	NAME AL	DATE 02-09-22	TITLE: SPLIT 7X100-60 XM
	CHECKED	Processes:		DWG NO. 157890
PROPRIETARY AND CONFIDENTIAL THE INFORMATION CONTAINED IN THIS DRAWING IS THE SOLE PROPERTY OF VENSET A/S. ANY REPRODUCTION IN PART OR AS A WHOLE WITHOUT THE WRITTEN PERMISSION OF VENSET A/S IS PROHIBITED.	WEIGHT:		REVISION 0	

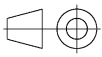
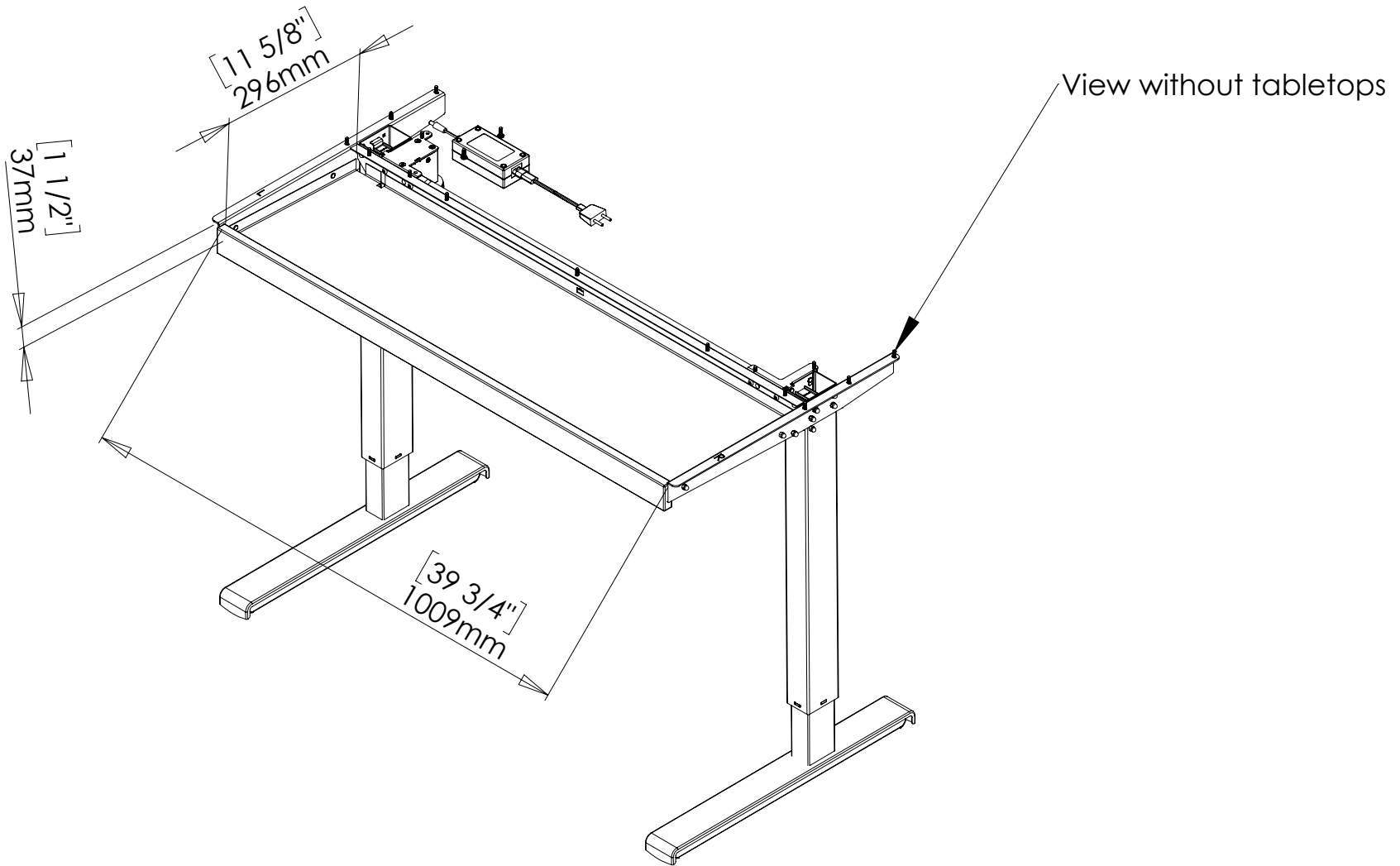
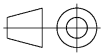

DO NOT SCALE DRAWING	SHEET 35 OF 39			ConSet A/S Industrivej 23 DK-6900 Skjern Denmark
UNLESS OTHERWISE SPECIFIED: DIMENSIONS ARE IN MILLIMETERS TOLERANCES: LINEAR: According to ANGULAR: DIN 7168-m	DRAWN	NAME AL	DATE 02-09-22	TITLE: SPLIT 7X100-60 XM
	CHECKED			
PROPRIETARY AND CONFIDENTIAL THE INFORMATION CONTAINED IN THIS DRAWING IS THE SOLE PROPERTY OF VENSET A/S. ANY REPRODUCTION IN PART OR AS A WHOLE WITHOUT THE WRITTEN PERMISSION OF VENSET A/S IS PROHIBITED.	Processes:			DWG NO. 157890
	WEIGHT:			REVISION 0